



ECOMAX F504 DISHWASHER

With a high capacity of up to 60 racks per hour, this dishwasher is a reliable partner for club houses, bistros, and fast-food restaurants. The practical floor unit fits under every work counter.

FEATURES

- Electronic control with digital temperature indication for easy operation
- Rotating wash and rinse arms for an even water distribution
- Indented nozzles prevent blocking
- Integrated counter for cycles and water consumption, e.g. for control of water treatment system
- Deep drawn rack track for easy cleaning
- USB connection for easier service access
- Incl. connection cable, supply and drain hose for immediate operation
- Thermostop function for guaranteed temperatures
- Self-cleaning programme for hygienic cleanliness also in the machine
- Tank strainer reduces soiling of the tank water
- Optional cabinet base for ergonomic operation



FEATURES

 MODELS	GLASSWASHER		plus	DISHWASHER		plus	plus	plus
	G404-10B	G404-32B	G415-11A	F504-10B	F504-30/32B	F515-11A	F515S-11A	F515-50A
Thermolabel compliant	●	●	–	●	●	–	–	●
Integrated water softener*	○	–	–	○	–	–	●	–
External water treatment system**	○	○	○	○	○	○	–	○
Double walled door	●	●	●	●	●	●	●	●
Double-walled housing	–	–	●	–	–	●	●	●
Deep-drawn wash tank	–	–	●	–	–	●	●	●
Door damping control	–	–	●	–	–	●	●	●
Tank strainer	–	–	●	●	●	●	●	●
Drain pump	○	○	●	○	○	●	●	●
Rinse pressure pump ***	–	–	●	●	–	●	●	●
Rinse aid dispenser	●	○	●	●	○	●	●	●
Detergent dispenser	○	○	●	○	○	●	●	●
Base cabinet (435 mm high) with removable front panel	–	–	○	○	○	○	○	○
Glass rack (4 sloped rows)	●	●	●	○	○	○	○	○
Glass rack (flat)	○	○	●	○	○	○	○	○
Plate rack P-18-12	–	–	–	●	●	●	●	●
Cutlery box CB-1	●	●	–	●	●	○	○	○
Cutlery rack CB-4	–	–	–	○	○	●	●	●
Universal flat rack B-00-07	–	–	–	○	○	●	●	●

* For machine protection the water hardness should not exceed 3°dH, if higher we recommend using an integrated water softener or an external water treatment system.

** For use of an external water treatment system, an integrated rinse pressure pump is necessary.

*** Necessary flow pressure without rinse pressure pump: 2-6 bar. Flow pressure with integrated rinse pressure pump: 0,8-6 bar

● inclusive ○ optional – not available

TECHNICAL SPECIFICATIONS

made in germany

MODELS	ecomax [™] by HOBART				ecomax [™] plus by HOBART		
	G404-10B	G404-32B	F504-10/30B	F504-32B	G415-11A	F515-11A	F515-50A
Cycle times*	60 / 120 sec.	60 / 120 sec.	60 / 150 sec.	60 / 150 sec.	60/120/180 sec.	60/120/180 sec.	60/120/180 sec.
Capacity cycles	60 /h	60 /h	60 /h	60 /h	60 /h	60 /h	60 /h
Tank capacity	10 l	10 l	25 l	25 l	8 l	10.6 l	10.6 l
Water consumption	2 l/rack	2 l/rack	2.3 l/rack	2.3 l/rack	2.0 l/rack	2.3 l/rack	2.3 l/rack
Wash pump	0.2 kW	0.2 kW	0.35 kW	0.35 kW	0.4 kW	0.5 kW	0.5 kW
Tank heating	1.8 kW	1.9 kW	1.8 kW	1.8 kW	0.8 kW	0.8 kW	1.7 kW
BOOSTER HEATING							
Standard	1.9 kW (230 V)	1.9 kW	5.6 kW (400 V)	3.7 kW (1P)	2.8 kW (230 V)	6.2 kW (400 V)	6.2 kW
Alternative	5.6 kW (400 V)	3.7 kW	1.9 kW (230 V)	5.5 kW (3P)	4.2 kW (400 V)	2.1 kW (230 V)	–
TOTAL LOADING							
Standard	2.1 kW (230 V)	2.1 kW	5.9 kW (400 V)	4.1 kW (1P)	3.2 kW (230 V)	7.5 kW (400 V)	8.4 kW
Alternative	5.8 kW (400 V)	3.9 kW	2.2 kW (230 V)	5.9 kW (3P)	5.4 kW (400 V)	3.4 kW (230 V)	–
Rated voltage	230/50/1 (400/50/3N)	230/60/1	400/50/3N (230/50/1)	230/60/1 (230/60/3)	230/50/1 (400/50/3N)	400/50/3N (230/50/1)	380-415/50/3N
Width	436 mm	436 mm	576 mm	576 mm	460 mm	600 mm	600 mm
Depth	534 mm	534 mm	604 mm	604 mm	590 mm	600 mm	600 mm
Height	700 mm	700 mm	820 mm	820 mm	705 mm	825 mm	825 mm
Loading height	308 mm	308 mm	360 mm	360 mm	315 mm	425 mm	425 mm
Rack size	390 x 390 mm	390 x 390 mm	500 x 500 mm	500 x 500 mm	400 x 400 mm	500 x 500 mm	500 x 500 mm

* The machines are equipped with an automatic cycle-time control which ensures hygienic rinse temperatures even on a cold-water supply or with reduced heating performance.

DRAWINGS



Glasswasher model **G404**

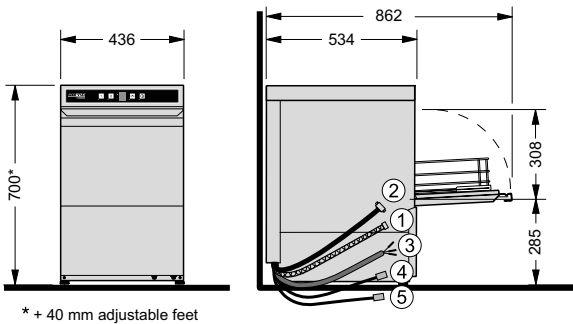

* + 40 mm adjustable feet



Glasswasher model **G415**

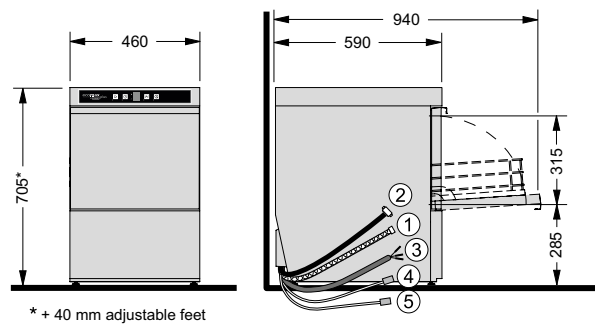

* + 40 mm adjustable feet

Undercounter dishwasher model **F504**

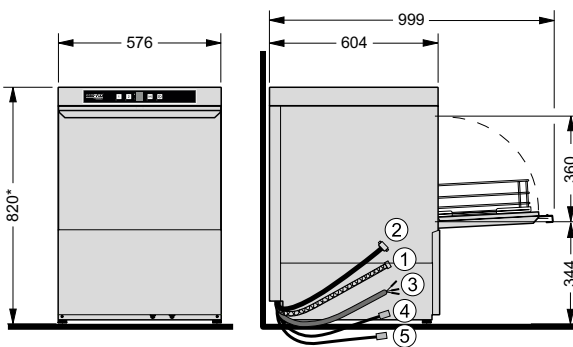

* + 40 mm adjustable feet

Undercounter dishwasher model **F515**

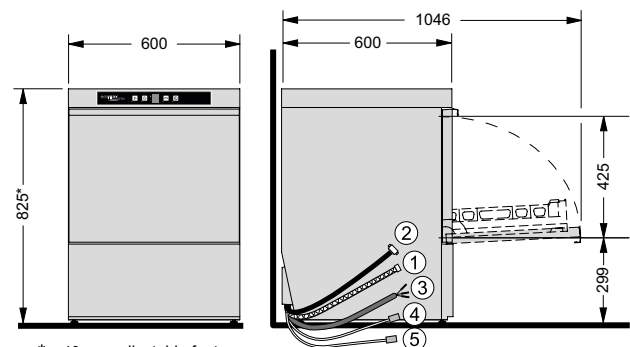

* + 40 mm adjustable feet

plus

- ① Drain hose
- ② Supply hose
- ③ Power cord
- ④ Detergent ^{a)}
- ⑤ Rinse aid ^{a)}

^{a)} depending on the device chemical dispensers are not included